

RSCDS London 90th Anniversary Grand Autumn Ball 2020

1 MISS HADDEN'S REEL J32 · 3/4L

RSCDS: RSCDS XXIII 5 · Crib: MiniCrib · Diagram: Keith Rose's Diagrams

- 1-8 1s+2s+3s circle 6H round & back
 9-16 1s set & cast (2s step up); 2s+1s+3s all turn RH to end in Allemande hold ready for ...
 17-24 2s+1s+3s dance Allemande
 25-32 3s+1s+2s Adv+Ret for 2 steps; 3s cast to 3rd place **while** 1s+2s dance up, 1s casting to 2nd place. 2 1 3 2nd turn bars 29-32: 3s cast to bottom & dance up to 3rd place, original 1s cast to bottom, 2s dance up to place

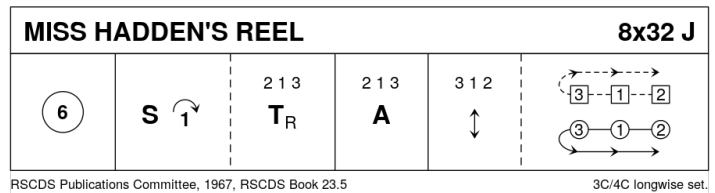

2 FRASER'S FAVOURITE R32 · 3/4L

John Laurie: The Leaflet Dances with Music · Crib: MiniCrib · Diagram: Keith Rose's Diagrams

- 1-8 1M+2L turn RH, 2M+1L turn LH 1.1/2 times to end facing partners
 9-16 1s+2s dance diagonal RSh reel of 4 (1s end in 2nd place)
 17-24 1s set advancing to end BtoB Lady facing up Man down & dance Crown Triangles
 25-32 1s dance RSh reel of 3 on opposite sides giving RSh to 2nd corners & cross back to 2nd place

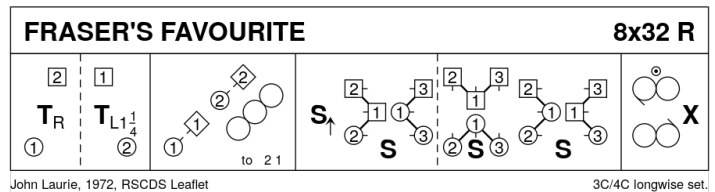

3 MISS MILLIGAN'S STRATHSPEY S32 · 3/4L

RSCDS: The Leaflet Dances with Music · Crib: MiniCrib · Diagram: Keith Rose's Diagrams

- 1-8 1s+2s circle 4H round to left, 1s face 2s NHJ with partners. 1s+2s set, 1s turning towards each to face up, then 1s cast **while** 2s dance up & face out
 9-16 2s+1s+3s dance reflection reels of 3 on own sides 1s dancing in between 3s to start. All take hands where possible
 17-24 2s+1s+3s set, 2s+1s 1/2 turn LH, 1s followed by 2s lead down between 3s, cross & cast up on own sides
 25-32 1s+2s dance the Knot

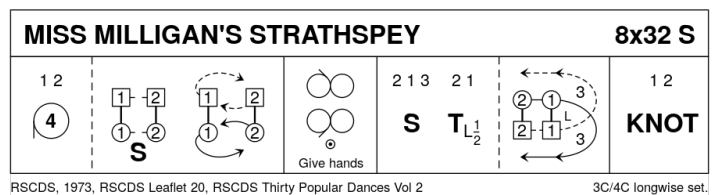

4 MISS ALLIE ANDERSON J32 · 3/4L

Mina Corson: The Leaflet Dances with Music · Crib: MiniCrib · Diagram: Keith Rose's Diagrams

- 1-8 1s+2s+3s all clap, 1L+2L+3L dance RSh round partners & 3s followed by 2s+1s lead down
 9-16 All 1/2 turn (Lady under Man's R arm) & 1s followed by 2s+3s lead back to top, 1s+2s+3s set & 1/2 turn partner RH ending in centre of dance
 17-24 1s+2s+3s dance Promenade
 25-32 1s+2L dance RH across, 1M ending in 2nd place (2M step up 27-28) 1s+2M dance LH across (2L step up 31-32) 1s end in 2nd place own side

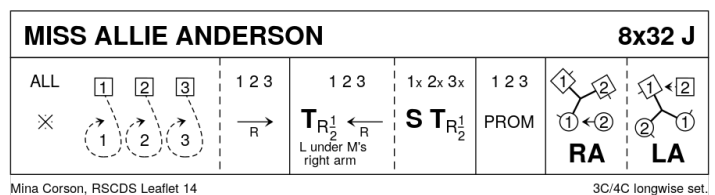

5 LADY SUSAN STEWART'S REEL R32 · 3/4L

RSCDS V 9 · Crib: MiniCrib · Diagram: Keith Rose's Diagrams

- 1-8 1s set, cast below 3s, lead up to top & cast to face 1st corners
 9-16 1s dance 'Hello-Goodbye' setting & end facing 1st corners
 17-24 1s turn 1st corners RH, partner LH, 2nd corners RH & partners LH to own sides facing down
 25-32 1s dance down between 3s, cast up on own side, dance up between 2s & cast back to 2nd place own sides

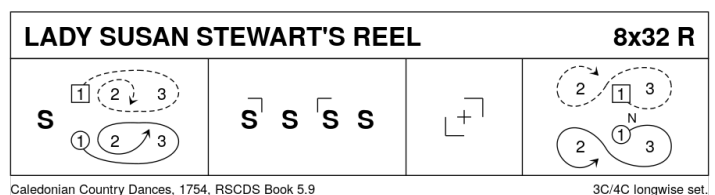

6 THE GENTLEMAN S32 · 3/4L

Roz Scott Huxley: RSCDS XXXV 5 · Crib: MiniCribs · Diagram: Keith Rose's Diagrams

- 1-8 1s turn 2H & remain in middle facing each other as 2s step up, 1s+2s set (1s advancing & pass LSh to face opposite partner) & dance 1/2 reel of 4 across with 2s with 1s ending reel giving LH to face down on own side between 2s
- 9-16 1s dance down to end between 3s & face each other, 1s+3s set (1s advancing & pass LSh to face opposite partner) & 1/2 reel of 4 across with 3s 1s end giving LH to face up on own side between 3s
- 17-24 1s lead up to top, cross over & cast to 2nd place & 1/2 reels of 3 across (L with 2s & M with 3s)
- 25-32 2s+1s dance Diamond Poussette

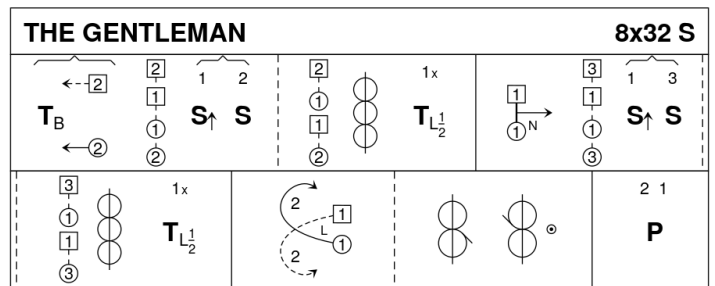

Roz Scott Huxley, 1986, RSCDS Book 35.5, RSCDS Thirty Popular Dances Vol 2 3C/4C longwise set.

7 THE DANCING MASTER J96 · 4S

John Drewry: Thirty Popular Dances, Volume Two · Crib: MiniCribs · Diagram: Keith Rose's Diagrams

- 1-8 1s & 3s set & pivot to right & dance round 1/4 cl'wise inside set (L follows M) & face in, 1s+3s change places with other partner RH & dance clockwise back to partners place (M follows L)
- 9-16 1s & 3s dance RH across with corner 2L/4L, 1s & 3s dance across & LH across with other corner 4M/2M to end in pl facing cl'wise (M behind L)
- 17-24 1s also 3s dance Tandem reels of 3 with corners, 1s & 3s ending in prom hold facing out
- 25-32 1s & 3s dance clockwise 1/2 way round outside of set & dance in back to original places (pass RSh) while 2s & 4s (prom hold) Adv+Ret
- 33-64 2s & 4s repeat above Figs from beginning (bars 1-32)
- 65-72 All set to partners & change place RH, Ladies dance 3/4 RH across while Men cast 1 place clockwise to meet opposite Lady
- 73-80 All repeat this Fig (bars 65-72) to end with own partners (opposite to where they started)
- 81-88 All dance 1/2 Schiehallion Reel (2 places) back to original places
- 89-96 All circle 8H round & back

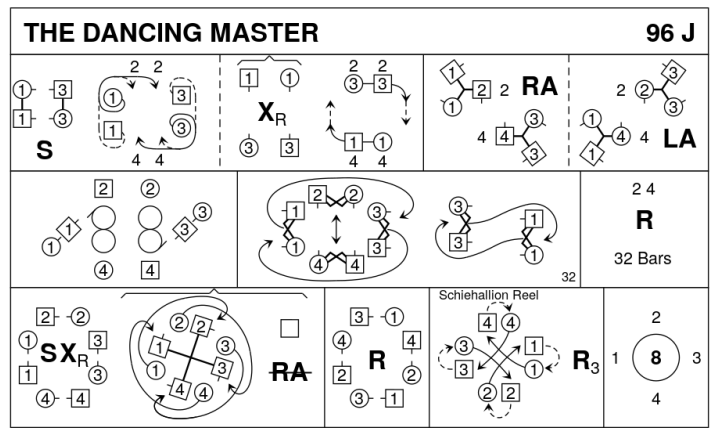

John Drewry, 1989, Donside Book, RSCDS Thirty Popular Dances Vol 2 4C/4C square set.

8 ARGYLL STRATHSPEY S32 · 3/4L

Roy Goldring: RSCDS XXXV 3 · Crib: MiniCribs · Diagram: Keith Rose's Diagrams

- 1-8 1s+2s+3s 1/2 turn RH, twirl & dance out to opposite sides & repeat back to place
- 9-16 1s+2s+3s circle 6H round & back (1s end in centre facing down & 3s in centre facing up)
- 17-24 1s+3s dance R&L (up & down) & end back on own sides
- 25-32 1s+2s dance the Tournee:
1s+2s dance into prom hold (Men with prtnr on right, 1s face M's side & 2s L's side), couples 1/2 wheel anticl'wise & Men turn Ladies into middle, both couples turn 1.1/2 times (2s RH, 1s LH) & dance out to places

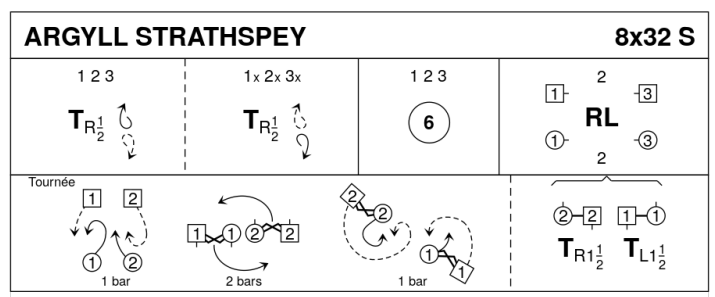

Goldring, 1985, RSCDS Book 35.3 3C/4C longwise set.

9 THE WESTMINSTER REEL R32 · 2/4L

Jeremy Hill: RSCDS XLV 1 · Crib: MiniCribs · Diagram: Keith Rose's Diagrams

- 1-8 1M+2L turn RH, 1L+2M turn RH 1.1/2 times end facing partner ready for diagonal reel of 4
- 9-16 1s+2s dance diagonal reel of 4
- 17-24 1s+2s Set & Rotate:
Set facing diagonally in, rotate singly & dance on 1 place clockwise, change places RH on sides & dance on 1 place to own sides (1s in 2nd pl)
- 25-32 2s+1s dance R&L

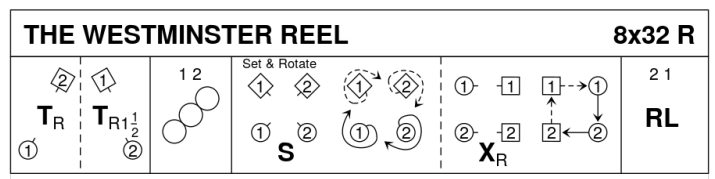

Jeremy Hill, London Jubilee Book, RSCDS Book 45.1 2C/4C longwise set.

10 MAJOR IAN STEWART J32 · 3/4L

John Drewry: RSCDS XXXV 4 · Crib: MiniCribs · Diagram: Keith Rose's Diagrams

- 1-8 1s+2s 1/2 turn partners RH & dance RH across 1/2 way, 2s+1s full turn partner RH ending with 2s at top & 1s in 2nd place
- 9-16 2s+1s+3s dance reels of 3 on own sides (1L dances in & up as 1M dances in & down to start) & 1s end facing 1st corners
- 17-24 1s dance 'Hello-Goodbye' setting ending with petronella turn to 2nd places
- 25-32 2s+1s+3s circle 6H round to the left for 6 steps, pivot & chase back to places

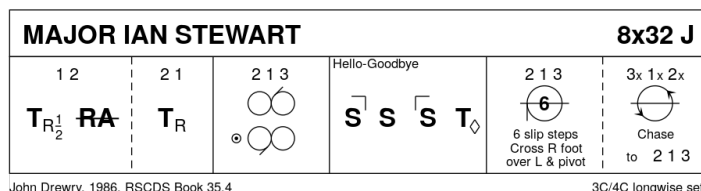

11 THE EARL OF MANSFIELD R48 · 4/4L

John Drewry: The Leaflet Dances with Music · Crib: MiniCribs · Diagram: Keith Rose's Diagrams

- 1-8 1s+2s circle 4H round & back
- 9-16 1s+2s also 3s+4s face on sides, all set & change places RH, all set & change back RH
- 17-24 1M reel of 3 with 2s (LSh to 2L) picking up partner in prom hold to complete reel as 3M dances similarly with 4s, 1s+3s end on Men's side
- 25-32 3s followed by 1s dance down below 4s, 3s cast, in & lead up to top, cross & cast back to place **while** 1s cast up & turn LH to face 1st crnrs
- 33-40 1s turn 1st corners RH pass partner RSh, turn 2nd corner LH, pass LSh to end 2nd place in centre facing up
- 41-48 1L+2L+3L dance RH across (on side) as 1M+2M+3M LH across, 1s followed by 3s dance down to 4s & Ladies dance LH across as Men RH across to end 2 3 4 1

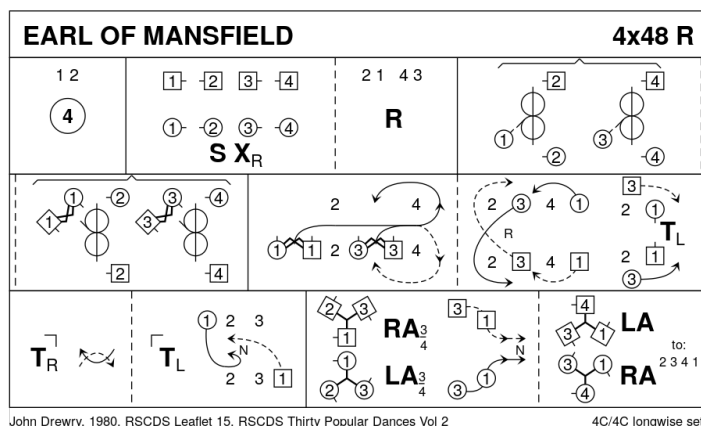

12 THE GLASGOW HIGHLANDERS S32 · 2/4L

RSCDS II 3 · Crib: MiniCribs · Diagram: Keith Rose's Diagrams

2 Ch - 1M stand as 1L crosses to 2M pl who crosses to ptrns pl, 2L steps up

- 1-8 1s+2s dance R&L ending with 2M between 1L+2L facing down 1M directly behind 2M
- 9-16 All dance down middle, turn right about & 1M dances Ladies back to top (2M follows) to form a line 4 across with Men BtoB facing partners
- 17-24 All set to partners with suitable step
- 25-32 All dance reel of 4 across ending in new pstns with each couple having moved 1 place anticlockwise round set
On bars 31/32 3M crosses to partners place as 3L steps up to start next 32 bars
Similarly on bars 31/32 (2nd time through) 4M crosses to partners places as 4L steps up

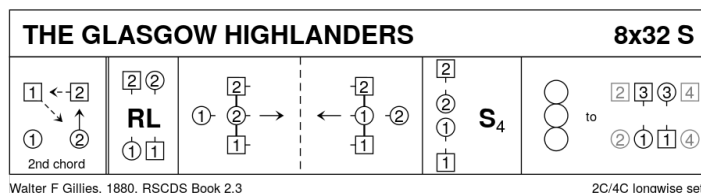

13 FAREWELL TO BALFOUR ROAD J32 · 5/5L

Andrew Buxton: RSCDS LII 7 · Crib: MiniCribs · Diagram: Keith Rose's Diagrams

- 1-8 1s+2s circle 4H round & back
- 9-16 1s+2s Set+Link; 1s+3s Set+Link
- 17-24 2s **start while** 1s+4s+5s dance mirror reels of 3 on sides (1s in/down to start)
- 25-32 1s set, cross down RH to 4th place (4s step up); 1s set, cross down LH to 5th place (5s step up)
New top couple start every 16 bars. Repeat until 1s back in 1st place, they stand for 16 bars while 5s continue bars 17-32 ending back in 5th place

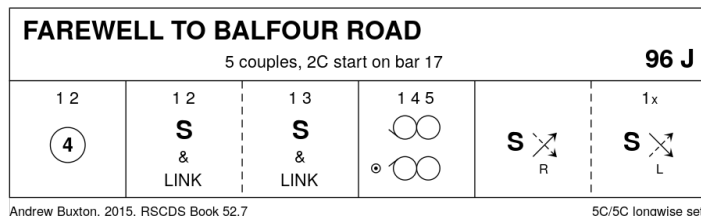

14 CRAMOND BRIDGE R32 · 3/4L

Valerie Farr: *The London Jubilee Book (1979)* · Crib: *MiniCribs* · Diagram: *Keith Rose's Diagrams*

- 1-8 1s cross RH & cast 1 place, cross LH & cast (Lady up, Man down), to meet in middle in prom hold facing 2nd Man
- 9-16 1s dance 1/2 diagonal reel with 1st corners & 1/2 reel with 2nd corners, end in middle facing Ladies' side
- 17-24 1s lead out, cross & cast (Lady up, Man down) to meet in middle, 1s turn RH as 2s+3s dance 1/2 R&L round them
- 25-32 1s lead up & cast to 2nd place & 2s+1s+3s turn partners RH

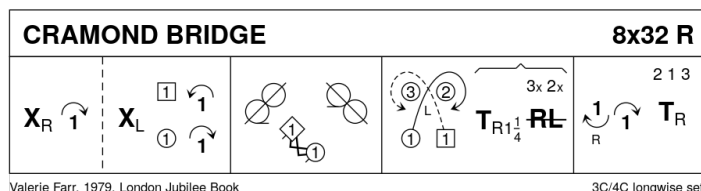

15 CULLA BAY S32 · 4S

Ann Dix: *RSCDS XLI 2* · Crib: *MiniCribs* · Diagram: *Keith Rose's Diagrams*

- 1-4 1s & 3s advance & 1/2 turn opposite partner RH & cast out to opposite side
- 5-8 1s & 3s chase 1/4 round set cl'wise & dance in passing 2s/4s RSh curving in to face 2s/4s as 2s & 4s repeat bars 1-4 & turn right about to face 1s/3s
- 9-16 All dance parallel reels of 4 across set
- 17-24 2s+1s also 4s+3s circle 4H once round to left, set & dance RH across 1/2 way
- 25-32 2s+4s dance LH across once round, 2s & 4s dance out through sides passing opp partner RSh & chase round set cl'wise to next place

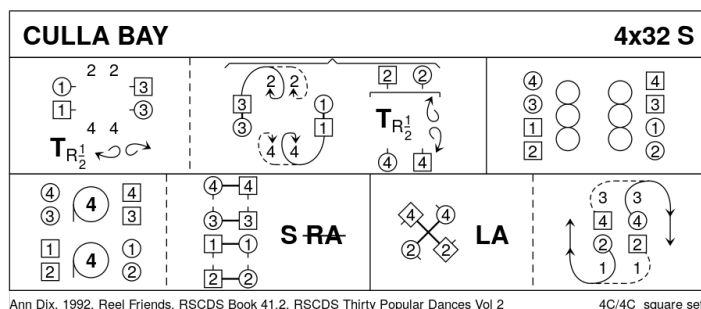

16 THE NEW RIGGED SHIP J48 · 3/4L

RSCDS IX 7 · Crib: *MiniCribs* · Diagram: *Keith Rose's Diagrams*

- 1-8 1s+2s circle 4H round & back
- 9-16 1s dance reels of 3 on own sides giving RSh to 2s
- 17-24 1s lead down the middle & back to top
- 25-32 1s cross RH, cast 1 place (3 bars), cross LH & cast to 3rd place (3 bars), begin to lead up (2 bars)
- 33-40 1s lead up to top & cast 1 place to face 1st corners. 1s set to 1st corner & to 2nd corner
- 41-48 1s dance reels of 3 on opposite sides giving RSh to 2nd corner & cross RH to own sides

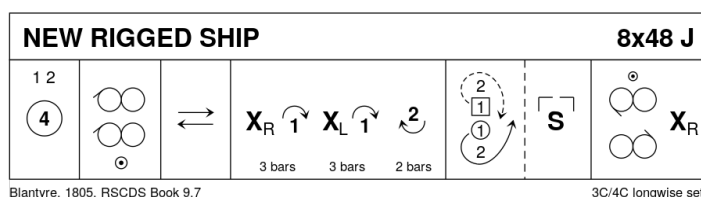

17 JEAN MARTIN OF ABERDEEN S32 · 3/3L

Muriel A Johnstone: *Magazine Dances 2005-2009* · Crib: *MiniCribs* · Diagram: *Keith Rose's Diagrams*

- 1-8 1s turn RH & cast 1 pl, all circle 6H round 3/4 way to left & end in lines of 3 across (Ladies face down & Men up)
- 9-16 All set & change places with partner RH, all circle 6H round 3/4 way to left & end in middle facing up. 3 1 2
- 17-24 All dance Allemande. 2 1 3
- 25-32 1s+3s (bottom 2 couples) dance the Bourrel to end 2 3 1 :
1M+3L set advg, 3/4 turn 2H & twirl to end BtoB (up/down middle L facing up & M down) **while** 1L+3M chase anticl'wise 1/2 way to face ptrnr
1s+3s set to partners & turn 2H to own sides having changed places

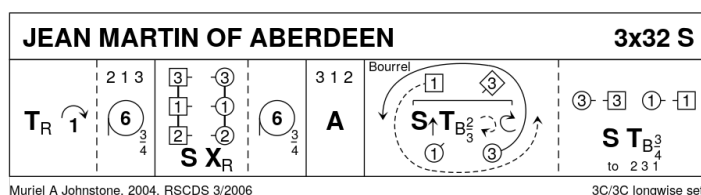

18 THE MONTGOMERIES' RANT R32 · 3/4L

Castle Menzies (18C): *RSCDS X 1* · Crib: *MiniCribs* · Diagram: *Keith Rose's Diagrams*

- 1-8 1s cross RH & cast down to 2nd place (2s step up), cross LH & 1L casts up **while** 1M casts down
- 9-16 1s dance reels of 3 across, 1L with 2s (RSh to 2M) & 1M with 3s (RSh to 3L)
- 17-24 1s NHJ (Lady on Mans left) set to 2L & turn inwards to set to 3M, set to 3L & turn inward & set to 2M. End facing own 2nd corner (1L pull back LSh to face down)
- 25-32 2s+1s+3s dance reels of 3 on opposite sides 1s giving RSh to 2nd corner, 1s cross RH to 2nd place own sides

